

Pro-Flo® SHIFT Series

simple.reliable.efficient.



WILDEN®

Where Innovation Flows

WILDEN®



Headquartered in Grand Terrace, CA, USA, Wilden was founded in 1955 by Jim Wilden when he revolutionized the pumping industry by inventing the air-operated double-diaphragm (AODD) pump. Since that time, Wilden has been recognized as the global leader in AODD pump technology, providing unique solutions to critical pumping applications with the most cost-effective, reliable and energy-efficient AODD pumps available.

Throughout its history, Wilden has made a commitment to the pursuit of excellence, customer satisfaction innovation, research

and development and market knowledge. It is this commitment, along with keeping alive the innovative spirit and customer-focused culture that Jim Wilden left behind, that has undoubtedly made Wilden one of the market leaders in the industry. By keeping these values in mind, Wilden also continues to set the standard in operation and performance, constantly introducing new technologies that will help bring AODD pumping technology into the future.



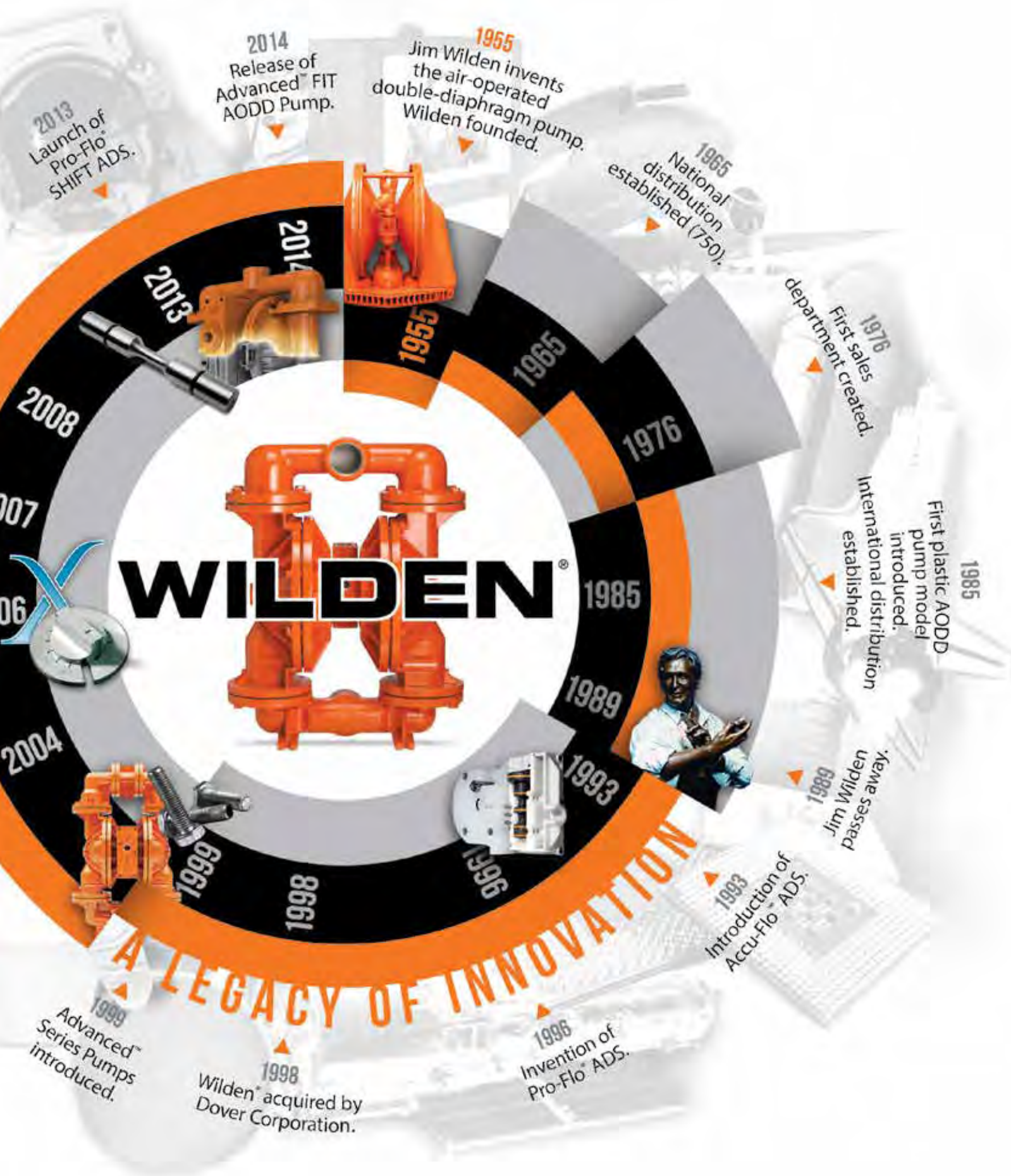

2013
Launch of
Pro-Flo®
SHIFT ADS.

2014
Release of
Advanced™ FIT
AODD Pump.

1955
Jim Wilden invents
the air-operated
double-diaphragm pump.
Wilden founded.

1965
National
distribution
established (750).

1976
First sales
department created.

1985
First plastic AODD
pump model
introduced.
International distribution
established.

1989
Jim Wilden
passes away.

1993
Introduction of
Accu-Flo™ ADS.

1996
Invention of
Pro-Flo® ADS.

1998
Wilden® acquired by
Dover Corporation.

1999
Advanced™
Series Pumps
introduced.

A LEGACY OF INNOVATION

WILDEN®

Working Principle of Wilden AODD Pumps

Wilden AODD pumps are reciprocating, positive-displacement-style pumps driven by compressed air. The following drawings and information detail the liquid flow pattern through the pump from its initial unprimed position.

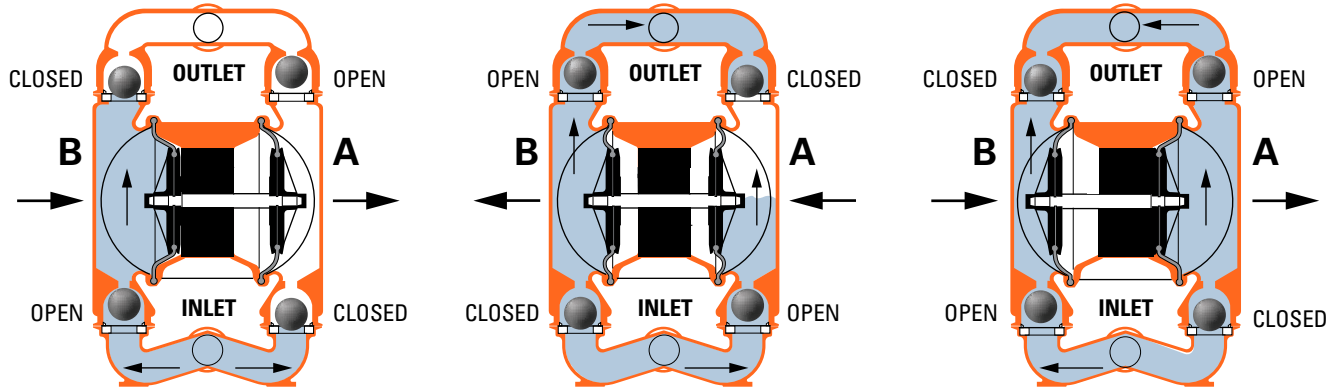

1. The air valve directs pressurized air to the back side of Diaphragm A.
2. The compressed air moves the diaphragm away from the center of the pump.
3. Diaphragm B is pulled in by the shaft connected to the pressurized Diaphragm A.
4. Diaphragm B is now on its suction stroke. The movement of Diaphragm B toward the center of the pump creates a vacuum within chamber B and causes the atmospheric pressure to force fluid into the inlet manifold forcing the inlet valve ball off its seat.
5. When the pressurized diaphragm, Diaphragm A, reaches the limit of its discharge stroke, the air valve redirects pressurized air to the back side of Diaphragm B.
6. The pressurized air forces diaphragm B away from the center while pulling Diaphragm A to the center.
7. Diaphragm B is now on its discharge stroke. Diaphragm B forces the inlet valve ball onto its seat due to the hydraulic forces.
8. The hydraulic forces lift the discharge valve ball off its seat, while the opposite discharge valve ball is forced onto its seat, forcing fluid to flow through the pump discharge.
9. At completion of the stroke, the air valve redirects air to the back side of diaphragm A, which starts diaphragm B on its exhaust stroke.
10. As the pump reaches its original starting point, each diaphragm has gone through one exhaust and one discharge stroke.

This constitutes one complete pumping cycle. The pump may take several cycles to completely prime depending on the conditions of the application.

Benefits of AODD Pumps







Thanks to their unique operating principle, AODD pumps excel in a wide variety of applications and incorporate numerous features and benefits, including:

- Self priming
- Portable
- High vacuum
- Lube-free operation
- No mechanical seals - reduces risk of leaks
- Run-dry capable
- No heat generation
- Submersible
- Superior product containment
- Easy installation
- Corrosion resistant
- Longest Mean Time Between Failure (MTBF)
- Anti-freezing



How AODD Compares to Other Pump Technologies

Air-operated double-diaphragm pumps provide a lot of unique benefits to all types of applications and markets.

A = Excellent B = Good C = Fair D = Poor		Shear Sensitivity	Dry-Run Capable	Solids Passage	Maintenance Costs	Submersible
Pump Type	 Wilden AODD Pumps	A	A	A	A	A
	 Vane Pumps	D	B	A	C	D
	 Gear Pumps	D	C	B	D	D
	 Lobe Pumps	A	C	C	D	D
	 Centrifugal Pumps	D	C	B	B	C
	 Peristaltic Hose Pumps	D	A	B	C	D
	 Piston/Plunger Pumps	C	A	C	D	D

Pro-Flo® Shift Applications

Serving the energy, process, hygienic, mining and water and wastewater markets, Wilden's world-class distributor network ensures that you will have access to the latest pump technologies and fluid transfer services available when you need them. To find a distributor closest to you, visit wildendistributor.com.

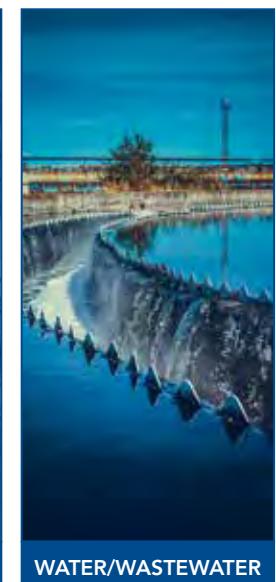



Wilden Pro-Flo® SHIFT Series pumps set the standard for AODD pump performance, providing increased energy savings and higher flow rates when compared to many competitor pumps. Combining the best of both worlds – industry-leading ADS with a top-quality AODD pump – Wilden Pro-Flo SHIFT Series pumps feature time- and field-proven performance, containment and maintenance advantages.

The secret to the success of the Pro-Flo SHIFT Series is a first-class design that comes equipped with industry-leading air valves that offer up to 60% energy savings and 34% greater flow rates when compared to other AODD Pump technologies. Additionally, the Pro-Flo SHIFT Series has been designed with increased suction lifts and fewer moving parts for increased reliability.

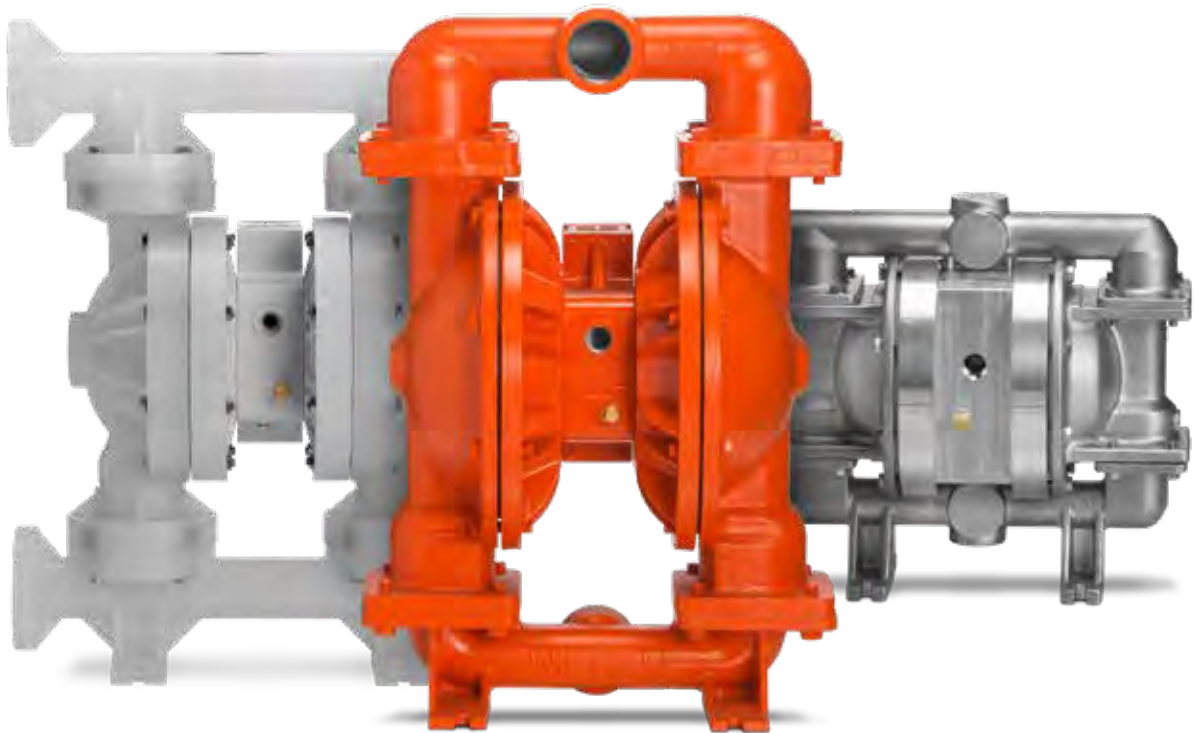

The Wilden Pro-Flo SHIFT is the premier air distribution system. The innovative, yet simple, Pro-Flo SHIFT design features an air control spool that automatically optimizes air consumption and eliminates the overcharging of the air chamber with no reduction in flow rate. This results in a reduction of air consumption and operational costs while maintaining maximum operational efficiency and volumetric consistency.

- Fewer operating parts, meaning less downtime and simplified maintenances
- Delivers more yield per SCFM versus competitive AODD pumps
- Longer diaphragm life
- Quiet operation

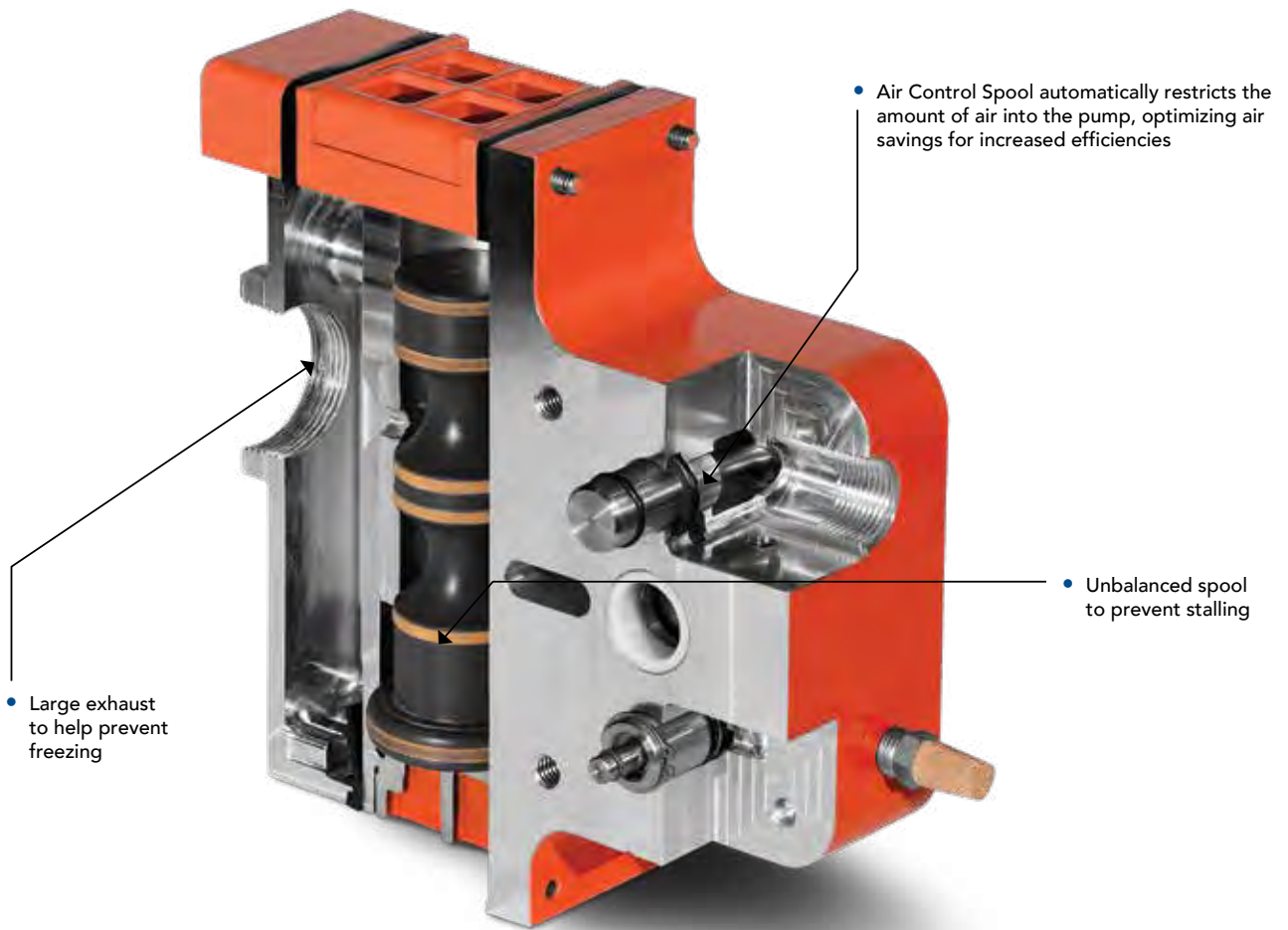

CE



Wilden Bolted Metal & Plastic Pumps

Wilden bolted metal and plastics pumps are specifically engineered for maximum performance and operational excellence in a variety of applications. Their bolted configuration ensures total product containment while the optimized liquid path reduces internal friction to maximize output and efficiency.

SIZE AND MATERIAL OPTIONS:

- Sizes: 25 mm (1") through 76 mm (3")
- Wetted Path Materials:
 - Metal: Aluminum, Ductile Iron, Stainless Steel, Alloy C
 - Plastic: Polypropylene, PVDF

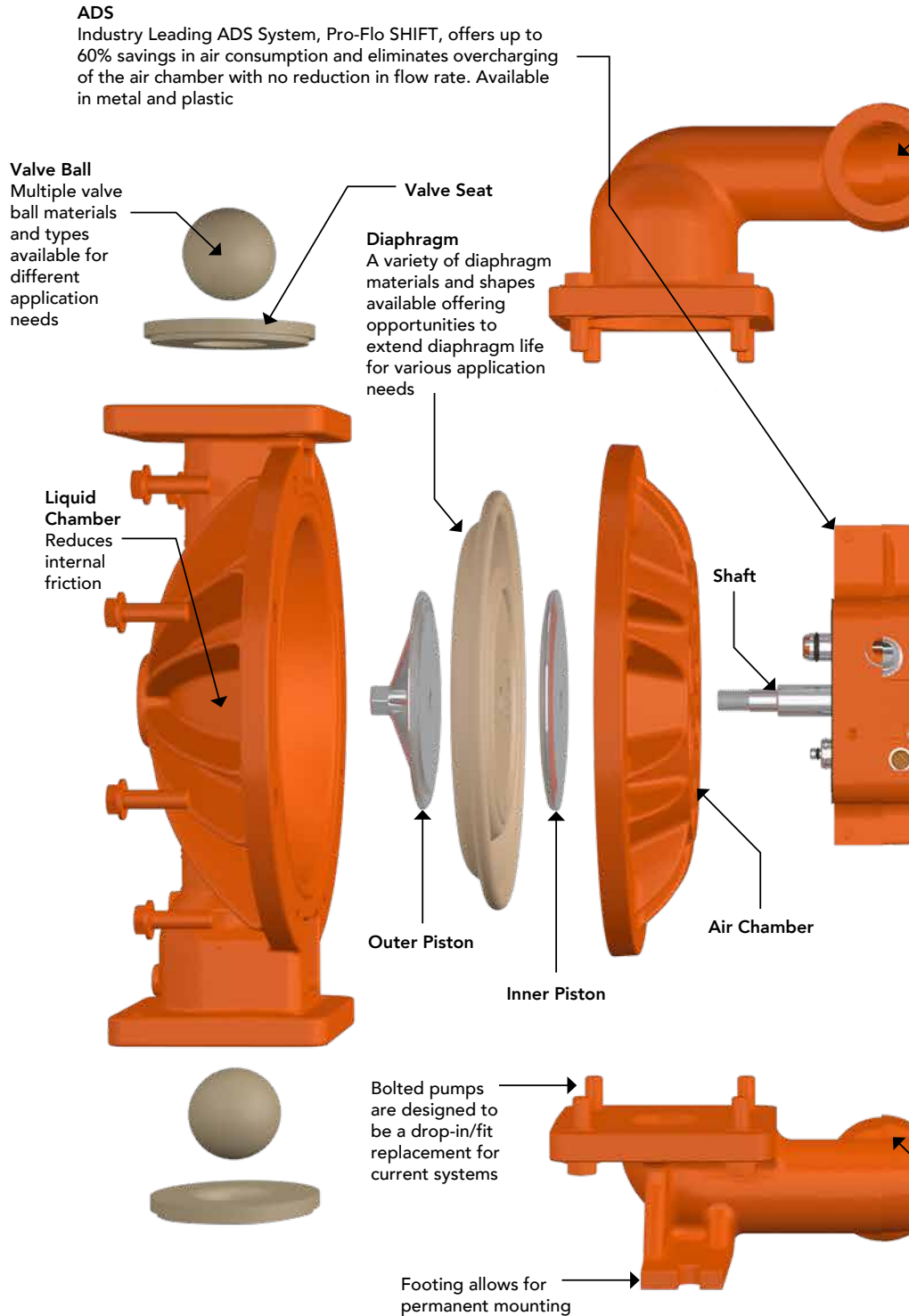

Series Connection Types

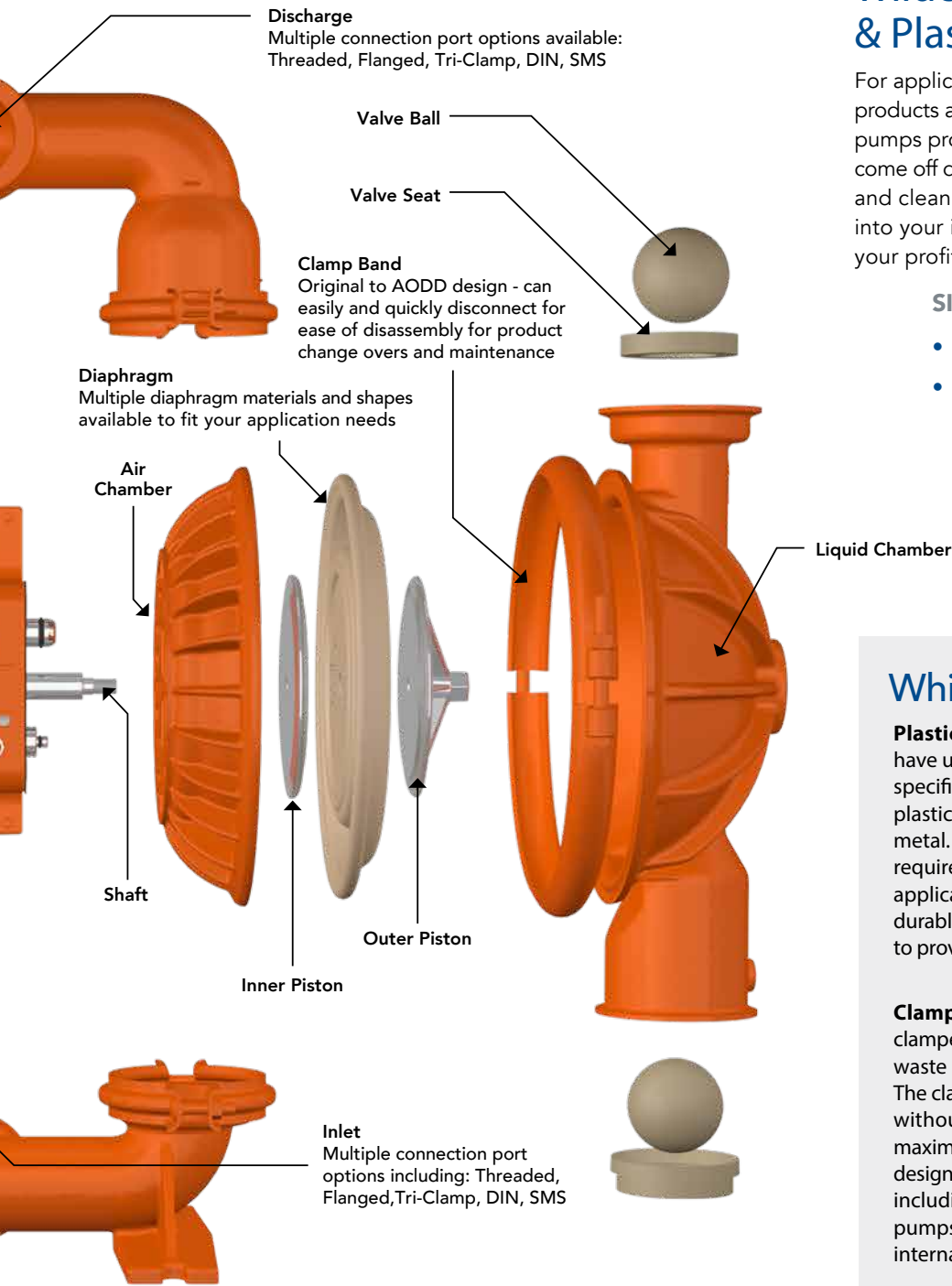

Wilden Clamped Metal & Plastic Pumps

For applications where constant changeovers between products are required, Wilden clamped metal and plastic pumps provide ease of maintenance. The clamp bands come off quickly and easily for replacement of diaphragms and cleaning. The lower downtime translates directly into your increased productivity and contributes to your profitability.

SIZE AND MATERIAL OPTIONS:

- Sizes: 13 mm (1/2") through 102 mm (4")
- Wetted Path Materials:
 - Metal: Aluminum, Cast Iron, Ductile Iron, Stainless Steel
 - Plastic: Polypropylene, PVDF

Which Pump Is Right For Me?

Plastic or Metal? – Plastic and metal pumps each have unique benefits and characteristics suited for your specific application needs. For chemical processes, plastic pumps typically provide greater resistance than metal. Hygienic processes on the other hand tend to require stainless steel. Additionally, general industrial applications benefit from aluminum and ductile iron's durable properties. Wilden has multiple material options to provide the exact pump needed for your application.

Clamped or Bolted? – The original AODD pump design, clamped pumps, lend themselves to various process and waste applications, as well as construction and mining. The clamped configuration provides easier maintenance without sacrificing reliability. Bolted pumps deliver maximum process fluid containment over clamp-banded designs, and can be used for a wide range of applications, including oil and gas, paints and inks, and acids. Bolted pumps also offer a redesigned liquid path that reduces internal friction to maximize output and efficiency.

Integral Piston Diaphragms (IPDs)

Wilden IPDs offer safe, clean and reliable product transfer with no product entrapment areas to minimize product contamination and risk liabilities. These diaphragms have a smooth, contoured shape and no outer piston. IPDs have greater durability and flex life and are compatible with existing shafts and supporting hardware. They also provide greater flow rates and faster installation.

CHEM-FUSE INTEGRAL PISTON DIAPHRAGM

Chem-Fuse diaphragms are the ideal solution for general industrial and chemical applications. Incorporating the core patented technology of Wilden's integral piston design, Chem-Fuse diaphragms solve many of the critical issues faced by industrial companies that use conventional diaphragms without sacrificing performance. This diaphragm features a wide range of temperature limits, excellent flex life, high abrasion resistance and outstanding durability, even when handling acids, caustics and other aggressive fluids. Additional benefits include:

- Up to 100% increased flow and suction lift compared to PTFE laminate diaphragms
- Elimination of potential leak point increases containment and safety when pumping critical or dangerous fluids
- Available in Wil-Flex™ and non-food grade Saniflex™ material
- Available sizes: 25 mm (1"), 38 mm (1-1/2"), 51 mm (2"), 76 mm (3"), 102 mm (4")

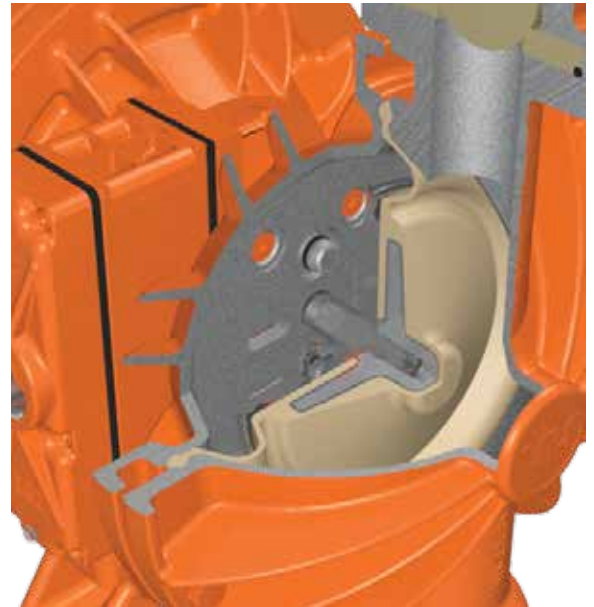

STANDARD DIAPHRAGM

GOOD
★★★★☆

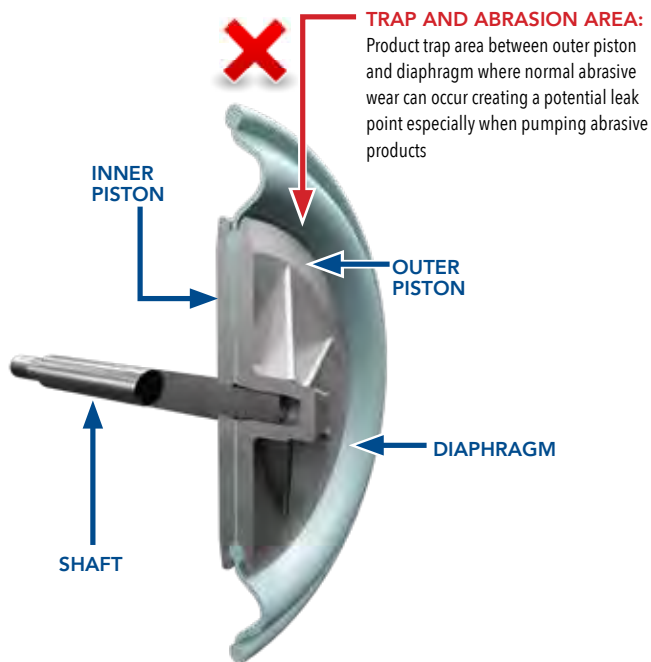

CHEM-FUSE DIAPHRAGM

BEST
★★★★★

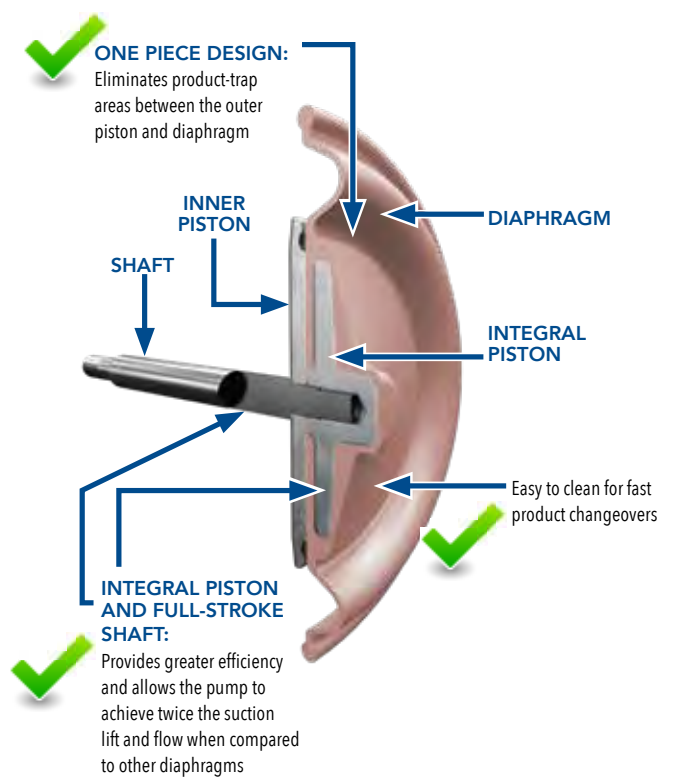

In addition, Wilden also offers a variety of other diaphragm options, including:

EZ-INSTALL

- Convolute shape allows quick, easy installation and minimizes risk of injury
- Decreased downtime and costs of diaphragm replacement
- Available in: Thermoplastic Elastomers (TPE) Wil-Flex, Saniflex™, Polyurethane and Geolast®
- 100% compatible with existing hardware

PTFE ELASTOMERS

- Optimal choice for aggressive chemical applications
- Excellent flex life, good abrasion resistance and durability
- Available in Reduced-Stroke PTFE and Full-Stroke PTFE

RUBBER ELASTOMERS

- General purpose diaphragm
- Provides the greatest temperature spans
- Increased chemical resistance
- Available in Buna-N, EPDM, Neoprene, and FKM

ULTRA-FLEX™

- Utilizes longest-lasting rubber-compound diaphragm in the industry
- Reduces internal stress for long diaphragm life
- Increased abrasion resistance with corrosive materials



Accessories

Wilden's accessory products add value to your liquid process and expand the application range of Wilden pumps by augmenting the performance and/or utility of the pump.

- **Equalizer® Surge Dampeners** - engineered to reduce fluid pressure and flow fluctuations that are inherent in AODD pumps, providing a smoother discharge flow. This function is critical in applications that need to minimize vibration and control pipe hammer which protects the piping system as well as downstream instrumentation
- **Wil-Gard™** - detects and notifies plant personnel when a diaphragm has ruptured to prevent further damage to pump
- **Pump Cycle Monitor (PCMI)** - counts pump cycles by sensing the presence of the air valve spool
- **Drum Pump Kit** - enables Wilden 6 mm (1/4") and 13 mm (1/2") pumps to adapt directly to drums for cost-effective, efficient liquid transfer



Repair and Retrofit Kits

Wilden wet and air repair kits for AODD pumps have been designed to help properly maintain the health and performance of your Wilden pump.

Always use only authentic Wilden air kits and wet kits when repairing or maintaining your Wilden products to preserve optimal performance and factory warranties.

- Easily order online at your convenience
- Kits are maintained and shipped in sealed packaging
- Include all necessary components for repair and maintenance

Wilden also offers retrofit kits which allow you to upgrade your existing pumps. Other spare parts outside of the traditional repair kits are available upon request.



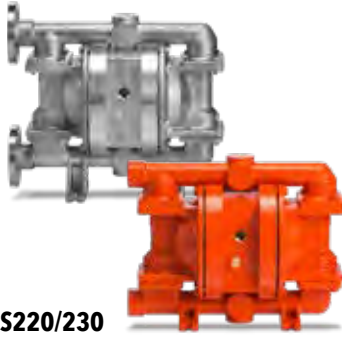

25 mm (1") PRO-FLO SHIFT BOLTED METAL PUMP

DESIGNATION: THREADED (PS220/A, PS220/S, PS220/W), FLANGED (PS230/S)



Air Inlet: 1/2" FNPT

Liquid Inlet: 25 mm (1")

Liquid Discharge: 25 mm (1")

Connection Type:

NPT/BSPT (Threaded)

DIN/ANSI (Flanged)

Max. Flow Rate:

212 lpm (56 gpm)

Max. Inlet Pressure:

8.6 bar (125 psig)

Max. Size Solids:

6.4 mm (1/4")

Max. Suction Lift:

6.9 m Dry (22.7')

9.0 m Wet (29.5')

Shipping Weight:

Aluminum 19 kg (41 lb)

Ductile Iron 29 kg (64 lb)

Stainless Steel 41 kg (68 lb)

PS220/230

Dimensions

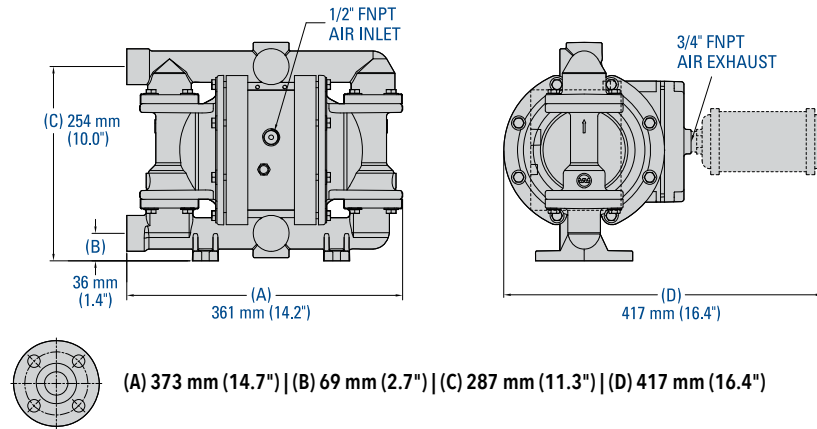

Note that dimensions vary by connection and material. For additional information, please refer to the PS220/230 Metal EOM.

Flow Curve TPE-FITTED

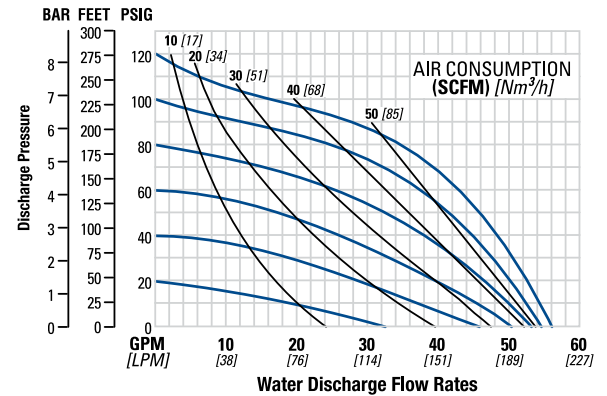

38 mm (1-1/2") PRO-FLO SHIFT BOLTED METAL PUMP

DESIGNATION: THREADED (PS420/A, PS420/S, PS420/W), FLANGED (PS430/A, PS430/S, PS430/W)



Air Inlet: 3/4" FNPT

Liquid Inlet: 38 mm (1-1/2")

Liquid Discharge: 38 mm (1-1/2")

Connection Type:

NPT/BSPT (Threaded)

DIN/ANSI (Flanged)

Max. Flow Rate:

510 lpm (135 gpm)

Max. Inlet Pressure:

8.6 bar (125 psig)

Max. Size Solids:

6.4 mm (1/4")

Max. Suction Lift:

6.2 m Dry (20.4')

9.3 m Wet (30.6')

Shipping Weight:

420 Threaded AL 26 kg (57 lb)

420 Threaded SS 50 kg (111 lb)

420 Threaded Iron 39 kg (86 lb)

430 Flanged AL 28 kg (62 lb)

430 Flanged SS 53 kg (116 lb)

430 Flanged Iron 42 kg (92 lb)

PS420/430

Dimensions

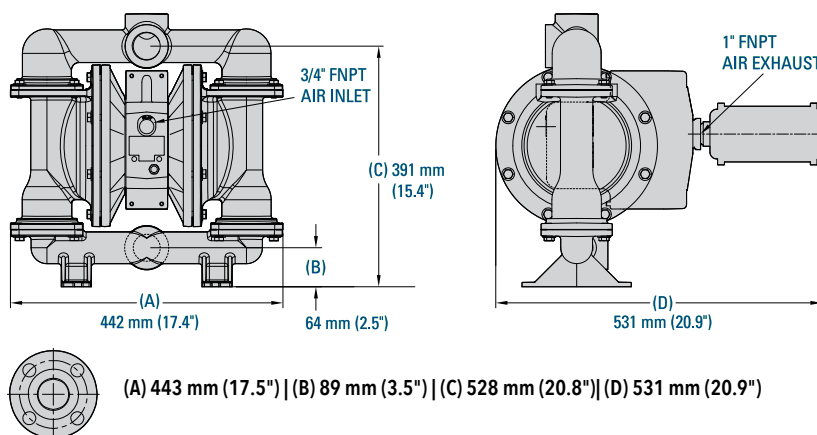

Note that dimensions vary by connection and material. For additional information, please refer to the PS420/430 Metal EOM.

Flow Curve EZ-INSTALL TPE-FITTED

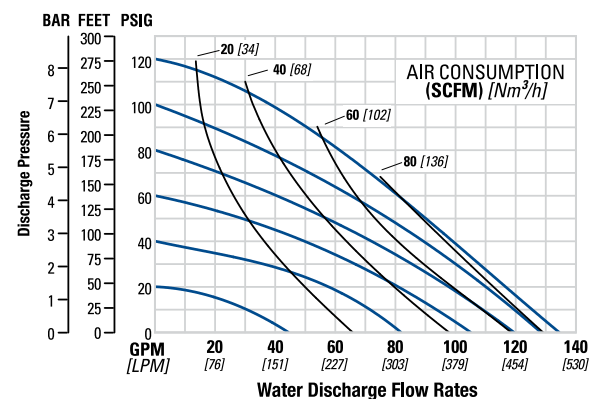



PS820/830

51 mm (2") PRO-FLO SHIFT BOLTED METAL PUMP

DESIGNATION: THREADED (PS820/A, PS820/S, PS820/W), FLANGED (PS830/A, PS830/S, PS830/W)



Air Inlet: 3/4" FNPT

Liquid Inlet: 51 mm (2")

Liquid Discharge: 51 mm (2")

Connection Type:

NPT/BSPT (Threaded)

DIN/ANSI (Flanged)

Max. Flow Rate:

685 lpm (181 gpm)

Max. Inlet Pressure:

8.6 bar (125 psig)

Max. Size Solids:

6.4 mm (1/4")

Max. Suction Lift:

7.1 m Dry (23.3')

9.0 m Wet (29.5')

Shipping Weight:

820 Threaded AL 47 kg (104 lb)

820 Threaded SS 73 kg (161 lb)

820 Threaded Iron 71 kg (156 lb)

830 Flanged AL 54 kg (118 lb)

830 Flanged SS 81 kg (178 lb)

830 Flanged Iron 82 kg (181 lb)

Dimensions

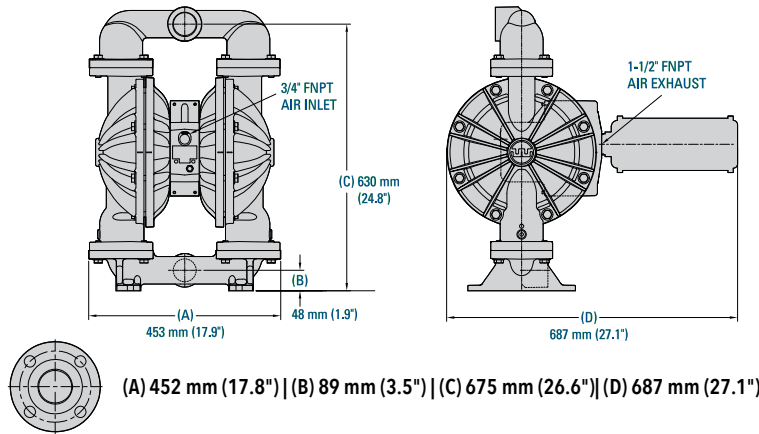

Note that dimensions vary by connection and material. For additional information, please refer to the PS820/830 Metal EOM.

Flow Curve EZ-INSTALL TPE-FITTED

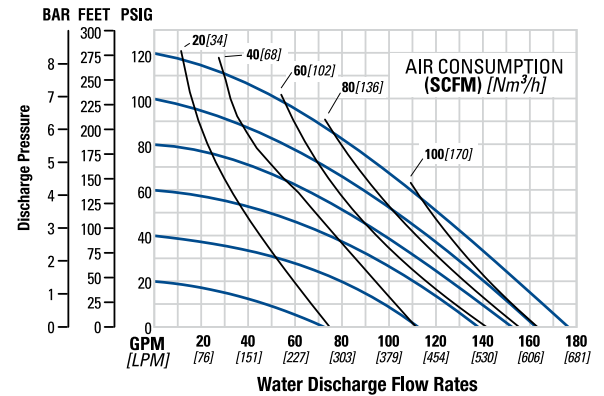

76 mm (3") PRO-FLO SHIFT BOLTED METAL PUMP

DESIGNATION: THREADED (PS1520/A, PS1520/S, PS1520/W), FLANGED (PS1530/A, PS1530/S, PS1530/W)

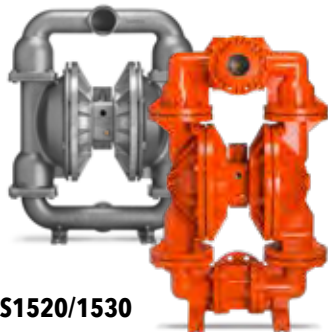

PS1520/1530

Air Inlet: 3/4" FNPT

Liquid Inlet: 76 mm (3")

Liquid Discharge: 76 mm (3")

Connection Type:

NPT/BSPT (Threaded)

DIN/ANSI (Flanged)

Max. Flow Rate:

1026 lpm (271 gpm)

Max. Inlet Pressure:

8.6 bar (125 psig)

Max. Size Solids:

12.7 mm (1/2")

Max. Suction Lift:

7.2 m Dry (23.8')

9.7 m Wet (31.8')

Shipping Weight:

1520 Threaded AL 69 kg (152 lb)

1520 Threaded SS 126 kg (278 lb)

1520 Threaded Iron 114 kg (251 lb)

1520 Flanged AL 101 kg (223 lb)

1530 Flanged SS 137 kg (300 lb)

1530 Flanged Iron 124 kg (272 lb)

Dimensions

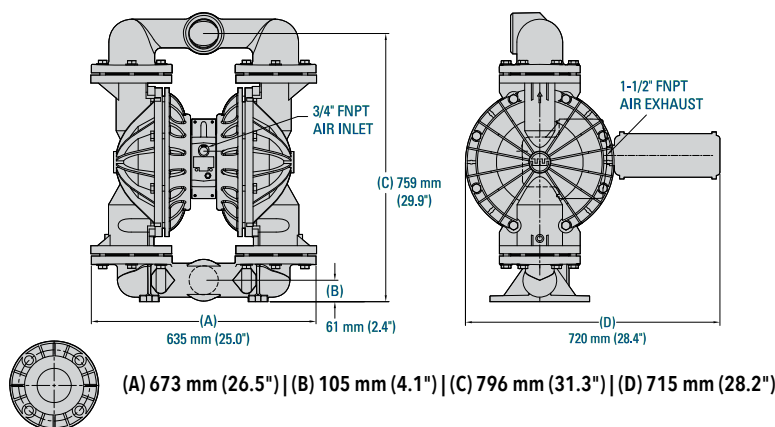

Note that dimensions vary by connection and material. For additional information, please refer to the PS1520/1530 Metal EOM.

Flow Curve EZ-INSTALL TPE-FITTED

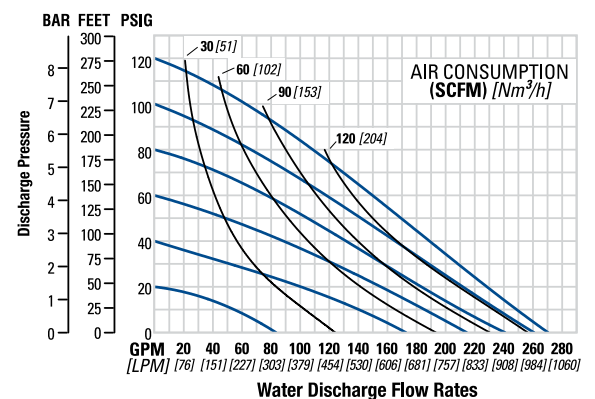



38 mm (1-1/2") PRO-FLO SHIFT BOLTED PLASTIC PUMP

DESIGNATION: FLANGED (PS400/K, PS400/P)



Air Inlet: 3/4" FNPT
 Liquid Inlet: 38 mm (1-1/2")
 Liquid Discharge: 38 mm (1-1/2")
 Connection Type: DIN/ANSI (Flanged)

Max. Flow Rate:
 458 lpm (121 gpm)
 Max. Inlet Pressure:
 8.6 bar (125 psig)
 Max. Size Solids:
 6.4 mm (1/4")

Max. Suction Lift:
 5.6 m Dry (18.4')
 9.0 m Wet (29.5')
 Shipping Weight:
 Polypropylene 28 kg (62 lb)
 PVDF 32 kg (70 lb)

PS400

Dimensions

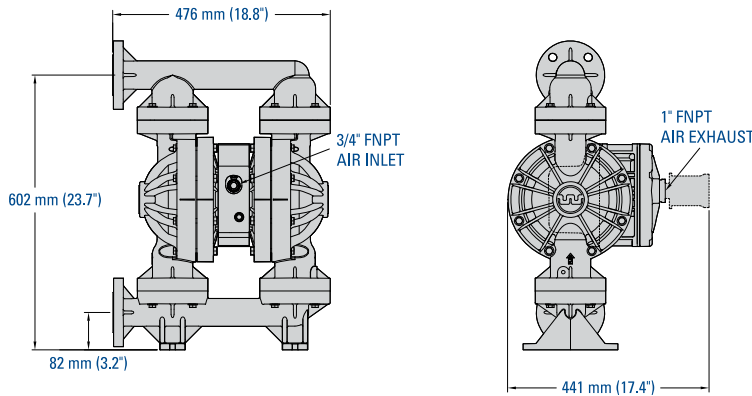

Note that dimensions vary by material and orientation. For additional information, please refer to the PS400 Plastic EOM.

Flow Curve EZ-INSTALL TPE-FITTED

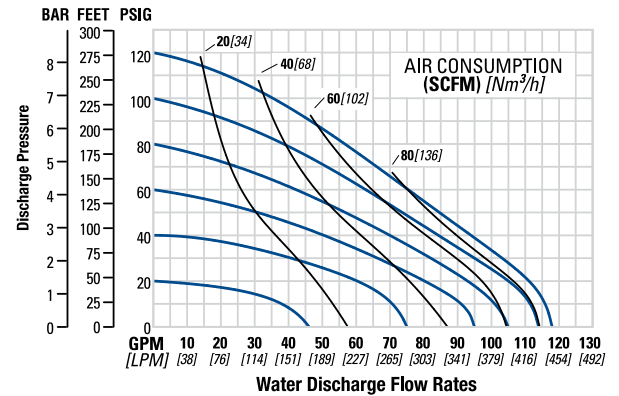

51 mm (2") PRO-FLO SHIFT BOLTED PLASTIC PUMP

DESIGNATION: FLANGED (PS800/K, PS400/P)



Air Inlet: 3/4" FNPT
 Liquid Inlet: 51 mm (2")
 Liquid Discharge: 51 mm (2")
 Connection Type:
 DIN/ANSI (Flanged)

Max. Flow Rate:
 709 lpm (187 gpm)
 Max. Inlet Pressure:
 8.6 bar (125 psig)
 Max. Size Solids:
 6.4 mm (1/4")

Max. Suction Lift:
 5.9 m Dry (19.3')
 8.3 m Wet (27.2')
 Shipping Weight:
 Polypropylene 40 kg (89 lb)
 PVDF 52 kg (115 lb)

PS800

Dimensions

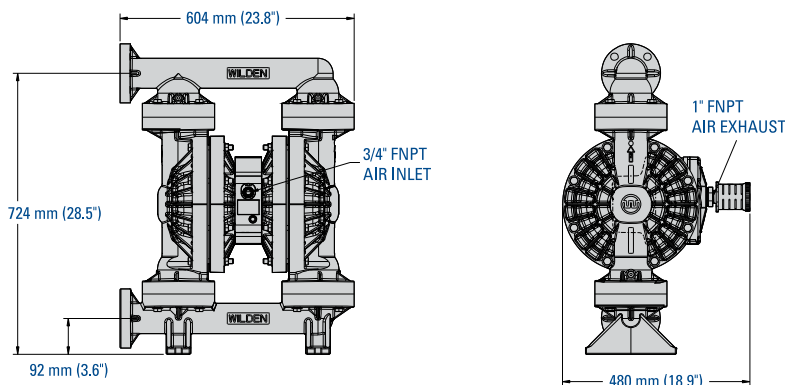

Note that dimensions vary by material and orientation. For additional information, please refer to the PS800 Plastic EOM.

Flow Curve EZ-INSTALL TPE-FITTED

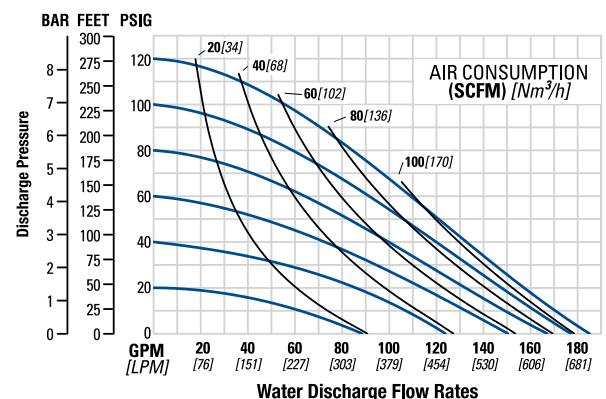

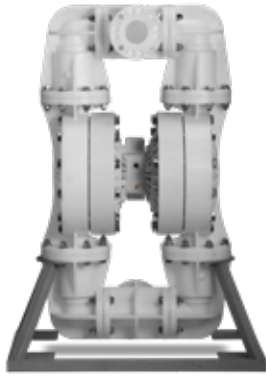

PS1500

76 mm (3") PRO-FLO SHIFT BOLTED PLASTIC PUMP

DESIGNATION: FLANGED (PS1500/K, PS1500/P)



Air Inlet: 3/4" FNPT

Liquid Inlet: 76 mm (3")

Liquid Discharge: 76 mm (3")

Connection Type:

DIN/ANSI (Flanged)

Max. Flow Rate:

1,024 lpm (271 gpm)

Max. Inlet Pressure:

8.6 bar (125 psig)

Max. Size Solids:

12.7 mm (1/2")

Max. Suction Lift:

5.8 m Dry (19.1')

8.6 m Wet (28.4')

Shipping Weight:

Polypropylene 125 kg (275 lb)

PVDF 152 kg (335 lb)

Dimensions

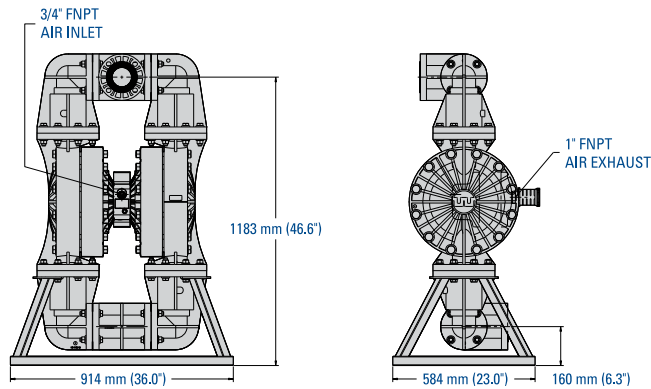

Note that dimensions vary by material and orientation. For additional information, please refer to the PS1500 Plastic EOM.

Flow Curve EZ-INSTALL TPE-FITTED

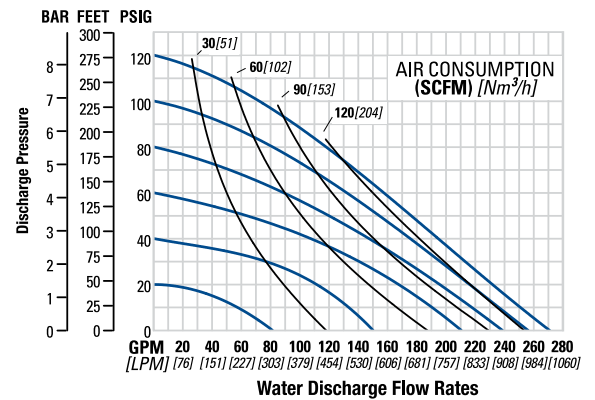

PS1

13 mm (1/2") PRO-FLO SHIFT CLAMPED METAL PUMP

DESIGNATION: THREADED (PS1/A, PS1/H, PS1/S)



Air Inlet: 1/2" FNPT

Liquid Inlet: 13 mm (1/2")

Liquid Discharge: 13 mm (1/2")

Connection Type:

NPT/BSPT (Threaded)

Max. Flow Rate:

60.2 lpm (15.9 gpm)

Max. Inlet Pressure:

8.6 bar (125 psig)

Max. Size Solids:

1.6 mm (1/16")

Max. Suction Lift:

5.9 m Dry (19.3')

9.8 m Wet (32.3')

Shipping Weight:

Aluminum 6 kg (13 lb)

Alloy C 9.5 kg (21 lb)

Stainless Steel 9 kg (20 lb)

Dimensions

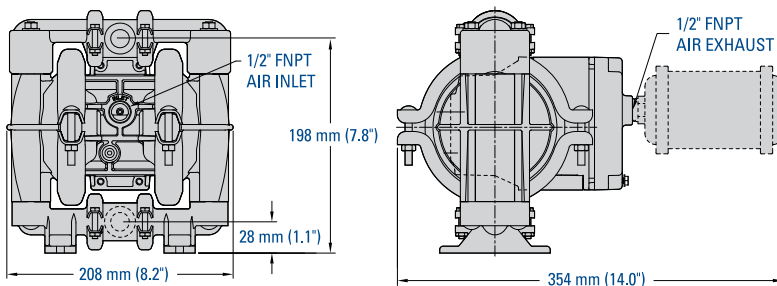

Note that dimensions vary by material. For additional information, please refer to the PS1 Metal EOM.

Flow Curve PTFE-FITTED

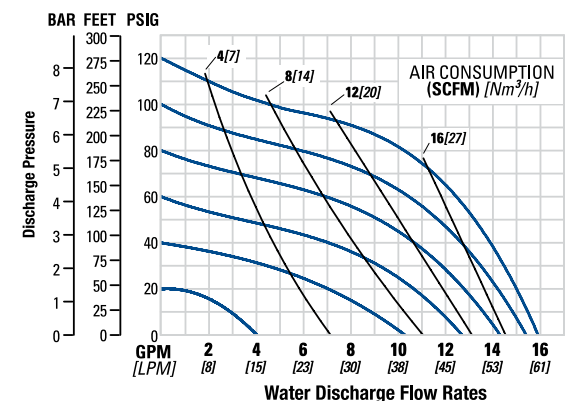



38 mm (1-1/2") PRO-FLO SHIFT CLAMPED METAL PUMP

DESIGNATION: THREADED (PS4/A, PS4/S, PS4/W)



Air Inlet: 3/4" FNPT

Liquid Inlet: 38 mm (1-1/2")

Liquid Discharge: 38 mm (1-1/4")

Connection Type:

NPT/BSPT (Threaded)

Max. Flow Rate:

375 lpm (99 gpm)

Max. Inlet Pressure:

8.6 bar (125 psig)

Max. Size Solids:

4.8 mm (3/16")

Max. Suction Lift:

7.1 m Dry (23.3')

8.6 m Wet (28.4')

Shipping Weight:

Aluminum 21 kg (46 lb)

316 Stainless Steel 28 kg (62 lb)

Ductile Iron 30 kg (66 lb)

PS4

Dimensions

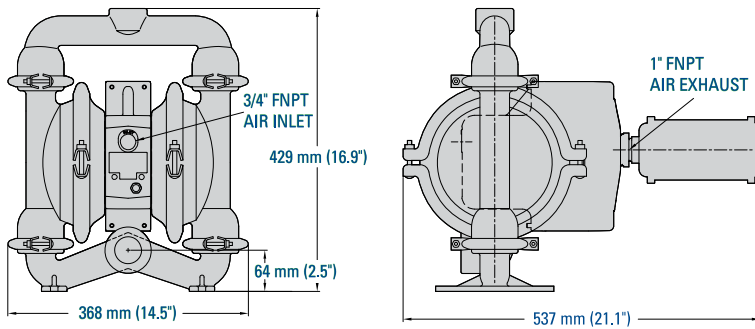

For additional information, please refer to the PS4 Metal EOM.

Flow Curve EZ-INSTALL TPE-FITTED

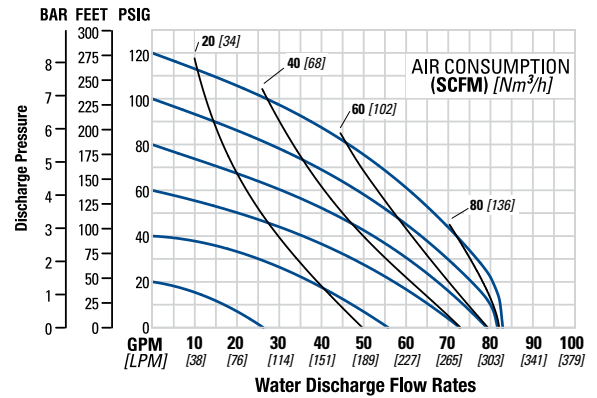

51 mm (2") PRO-FLO SHIFT CLAMPED METAL PUMP

DESIGNATION: THREADED (PS8/A, PS8/S, PS8/W)



Air Inlet: 3/4" FNPT

Liquid Inlet: 51 mm (2")

Liquid Discharge: 51 mm (2")

Connection Type:

NPT/BSPT (Threaded)

Max. Flow Rate:

723 lpm (191 gpm)

Max. Inlet Pressure:

8.6 bar (125 psig)

Max. Size Solids:

6.4 mm (1/4")

Max. Suction Lift:

7.2 m Dry (23.8')

9.0 m Wet (29.5')

Shipping Weight:

Aluminum 35 kg (78 lb)

316 Stainless Steel 53 kg (117 lb)

Ductile Iron 49 kg (109 lb)

PS8

Dimensions

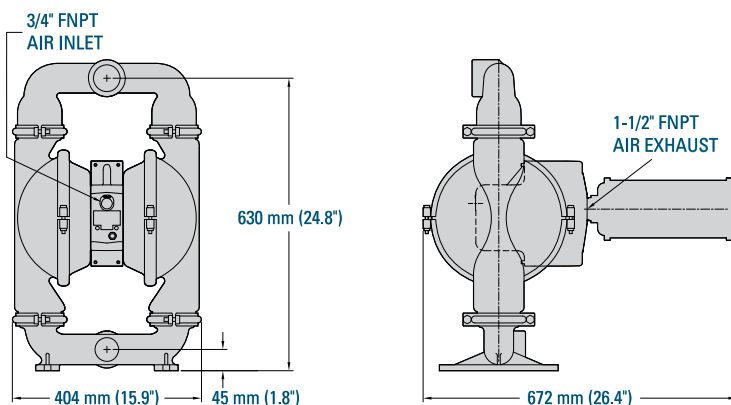

Note that dimensions vary by material. For additional information, please refer to the PS8 Metal EOM.

Flow Curve EZ-INSTALL TPE-FITTED

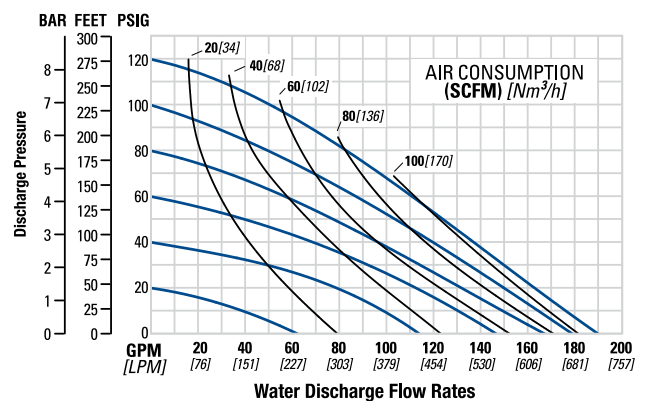

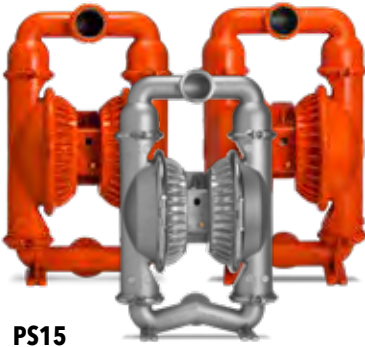

76 mm (3") PRO-FLO SHIFT CLAMPED METAL PUMP

DESIGNATION: THREADED (PS15/A, PS15/S, PS15/W)



Air Inlet: 3/4" FNPT

Liquid Inlet: 76 mm (3")

Liquid Discharge: 76 mm (3")

Connection Type:

NPT/BSPT (Threaded)

Max. Flow Rate:

927 lpm (245 gpm)

Max. Inlet Pressure:

8.6 bar (125 psig)

Max. Size Solids:

9.5 mm (3/8")

Max. Suction Lift:

6.6 m Dry (21.6')

8.6 m Wet (28.4')

Shipping Weight:

Aluminum 55 kg (121 lb)

316 Stainless Steel 105 kg (230 lb)

Ductile Iron 93 kg (205 lb)

PS15

Dimensions

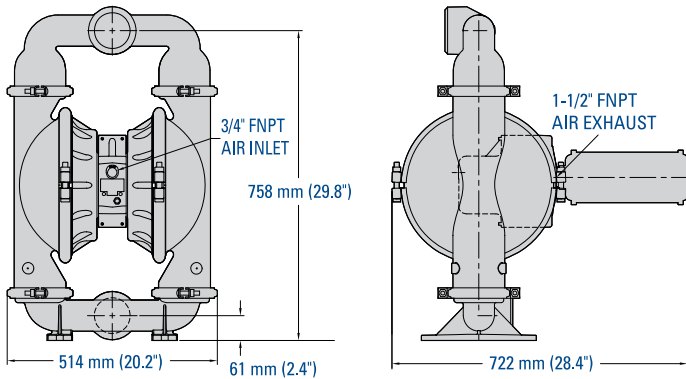

Note that dimensions vary by material. For additional information, please refer to the PS15 Metal EOM.

Flow Curve EZ-INSTALL TPE-FITTED

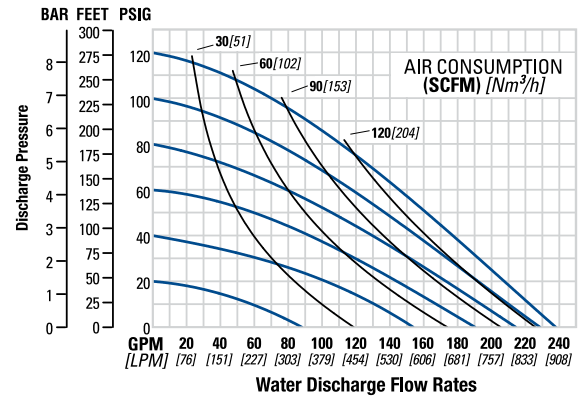

102 mm (4") PRO-FLO SHIFT CLAMPED METAL PUMP

DESIGNATION: FLANGED (PS20/W)



Air Inlet: 3/4" FNPT

Liquid Inlet: 102 mm (4")

Liquid Discharge: 102 mm (4")

Connection Type:

ANSI (Flanged)

Max. Flow Rate:

1048 lpm (277 gpm)

Max. Inlet Pressure:

8.6 bar (125 psig)

Max. Size Solids:

35 mm (1-3/8")

Max. Suction Lift:

4.4 m Dry (14.4')

8.6 m Wet (28.4')

Shipping Weight:

Ductile Iron 223 kg (492 lb)

PS20

Dimensions

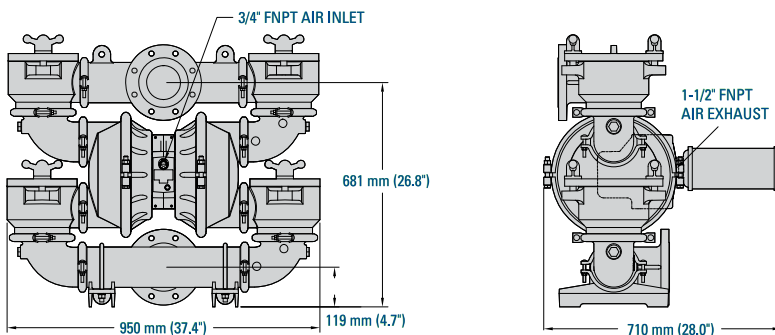

Note that dimensions vary by material. For additional information, please refer to the PS20 Metal EOM.

Flow Curve EZ-INSTALL TPE-FITTED

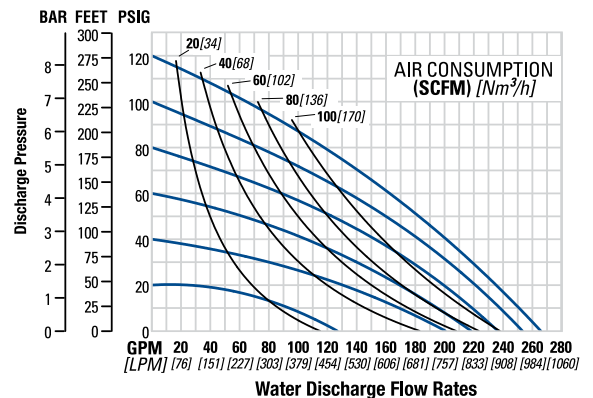



38 mm (1-1/2") PRO-FLO SHIFT CLAMPED PLASTIC PUMP

DESIGNATION: FLANGED (PS4/K, PS4/P)



Air Inlet: 3/4" FNPT

Liquid Inlet: 38 mm (1-1/2")

Liquid Discharge: 38 mm (1-1/2")

Connection Type:

DIN/ANSI (Flanged)

Max. Flow Rate:

379 lpm (100 gpm)

Max. Inlet Pressure:

8.6 bar (125 psig)

Max. Size Solids:

4.8 mm (3/16")

Max. Suction Lift:

6.2 m Dry (20.4')

8.3 m Wet (27.2')

Shipping Weight:

Polypropylene 18 kg (40 lb)

PVDF 24 kg (52 lb)

PS4

Dimensions

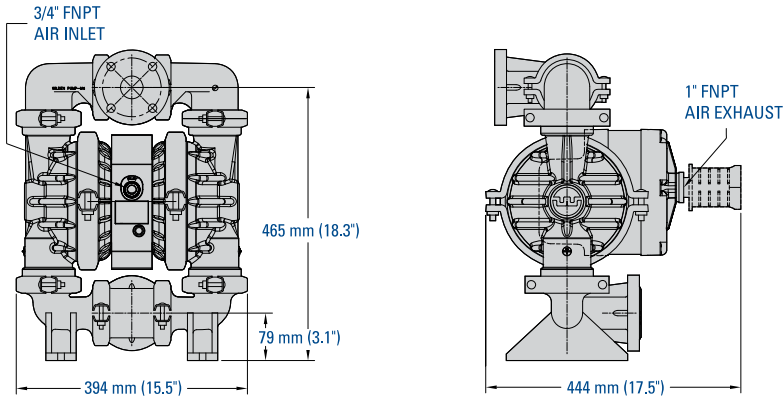

Note that dimensions vary by material. For additional information, please refer to the PS4 Plastic EOM.

Flow Curve EZ-INSTALL TPE-FITTED

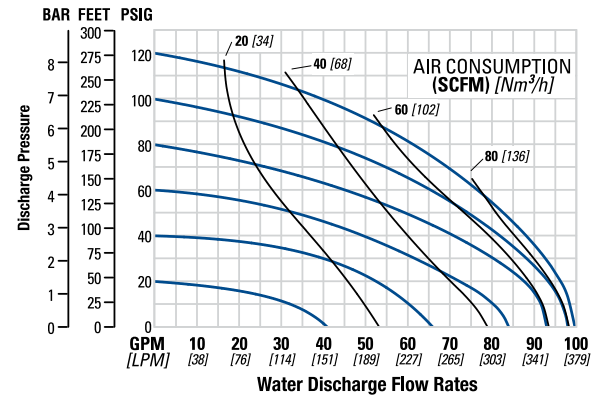

51 mm (2") PRO-FLO SHIFT CLAMPED PLASTIC PUMP

DESIGNATION: FLANGED (PS8/P)



Air Inlet: 3/4" FNPT

Liquid Inlet: 51 mm (2")

Liquid Discharge: 51 mm (2")

Connection Type:

DIN/ANSI (Flanged)

Max. Flow Rate:

643 lpm (170 gpm)

Max. Inlet Pressure:

8.6 bar (125 psig)

Max. Size Solids:

6.4 mm (1/4")

Max. Suction Lift:

6.6 m Dry (21.8')

8.3 m Wet (27.2')

Shipping Weight:

36 kg (79 lb)

PS8

Dimensions

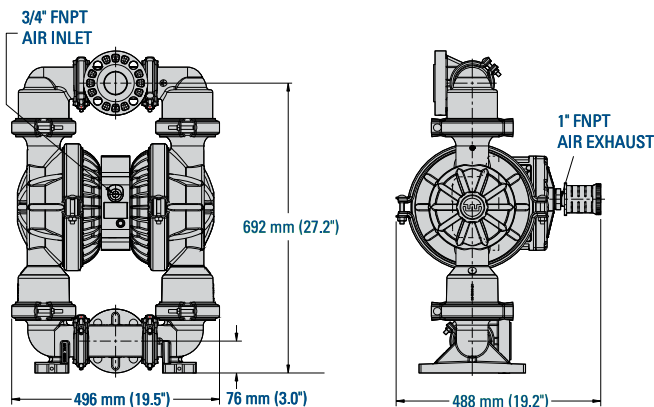

Note that dimensions vary by material. For additional information, please refer to the PS8 Plastic EOM.

Flow Curve EZ-INSTALL TPE-FITTED

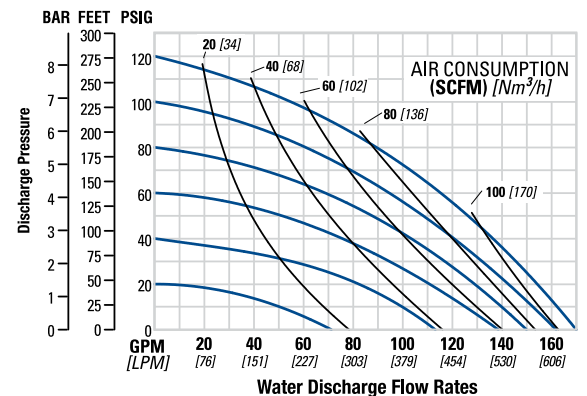

WILDEN®

PSG
22069 Van Buren Street
Grand Terrace
CA, 92313-5651
USA
P: +1 (909) 422-1730
F: +1 (909) 783-3440
wildenpump.com



Where Innovation Flows

WIL-19230-C-07

Authorized PSG® Partner:

Copyright 2022 PSG®, a Dover company